

CONSOLE ASSEMBLIES:

BASIC ENG - BAS-000X-0103

BASIC GER - BAS-020X-0103

ADVANCED ENG - ADV-000X-0103

ADVANCED GER - ADV-020X-0103

END CAP  
REX21MV  
END CAP SCREWS  
REXOKC6

X1 MODEL BADGE  
REX2G6Z

FRONT  
COMPONENTS

WATER BOTTLE  
REX2B96  
WATER BOTTLE HOLDER  
REX21CV  
MTG. SCREWS  
REXOK4R

Hardware Bag: REX2B06  
Touch-up Paint: 7967401  
Operation Manuals:

English - 8117901  
German - 8118001  
French - 8118101  
Spanish - 8118201  
Russian - 8118301

REAR  
COMPONENTS

MOVEMENT ARMS  
& HARDWARE

BLOCK  
DIAGRAM

CABLES

LF LOGO LABEL  
REX2ARH

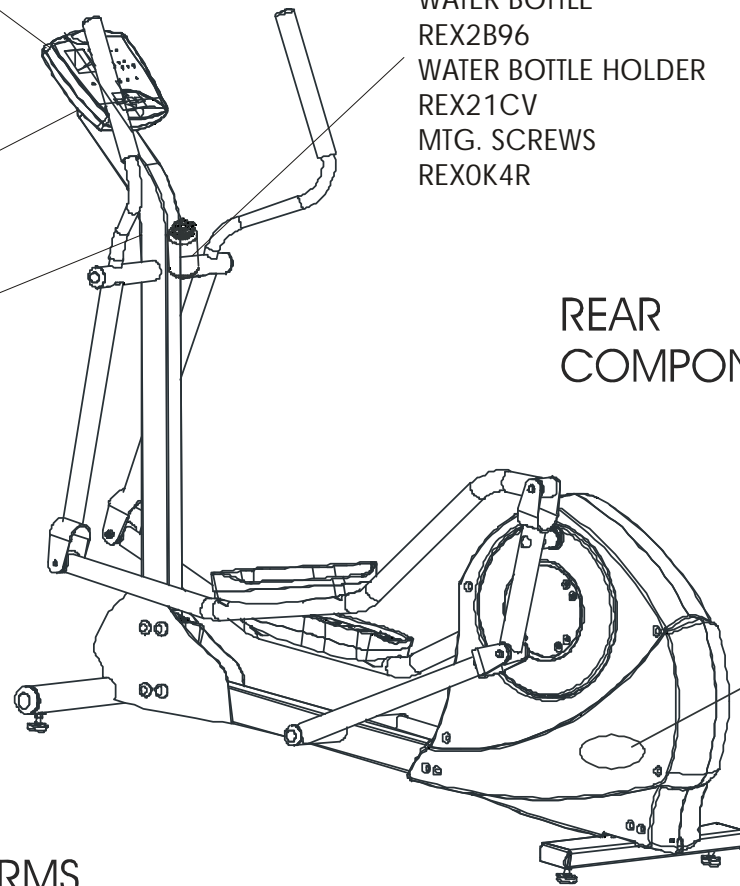

# LF Cross-Trainer Movement Arms and Hardware

X1-XX00-0103

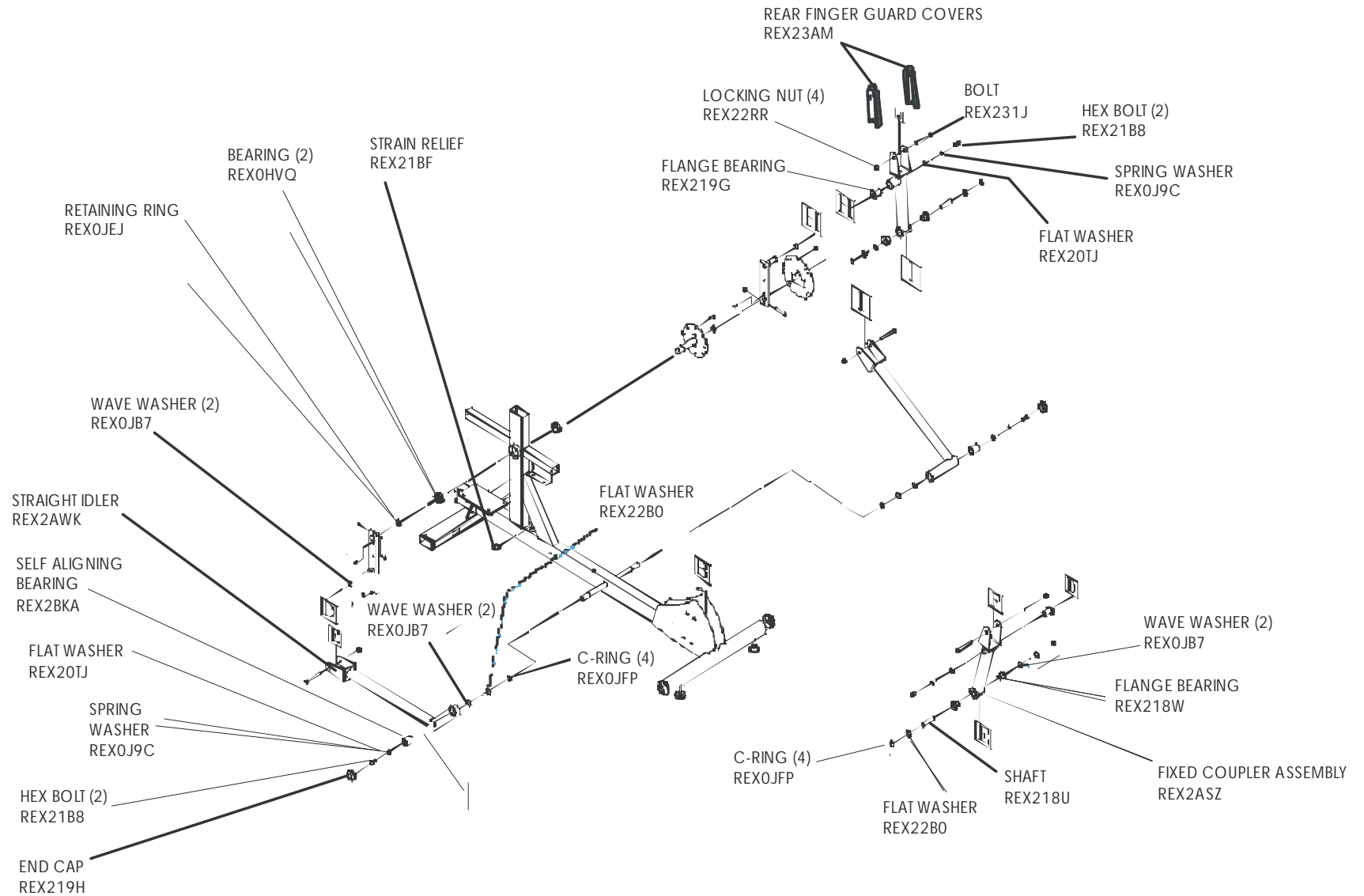

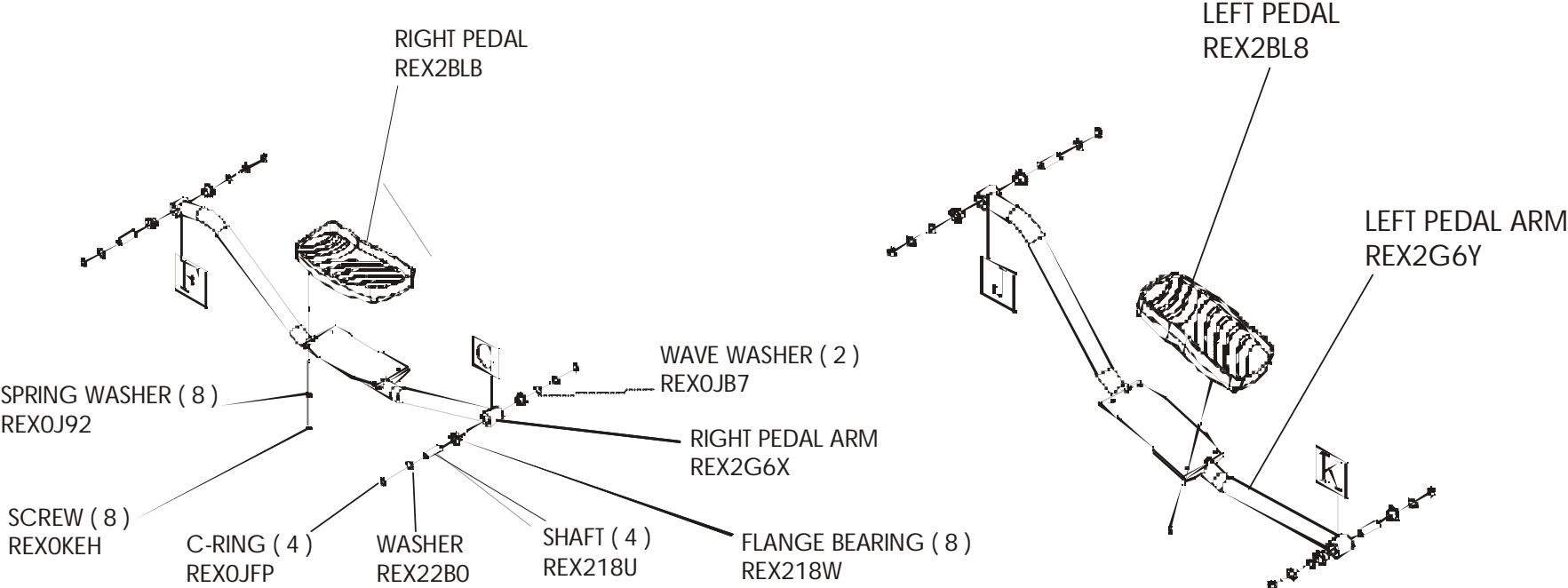

# LF Cross-Trainer Rear Components

X1-XX00-0103

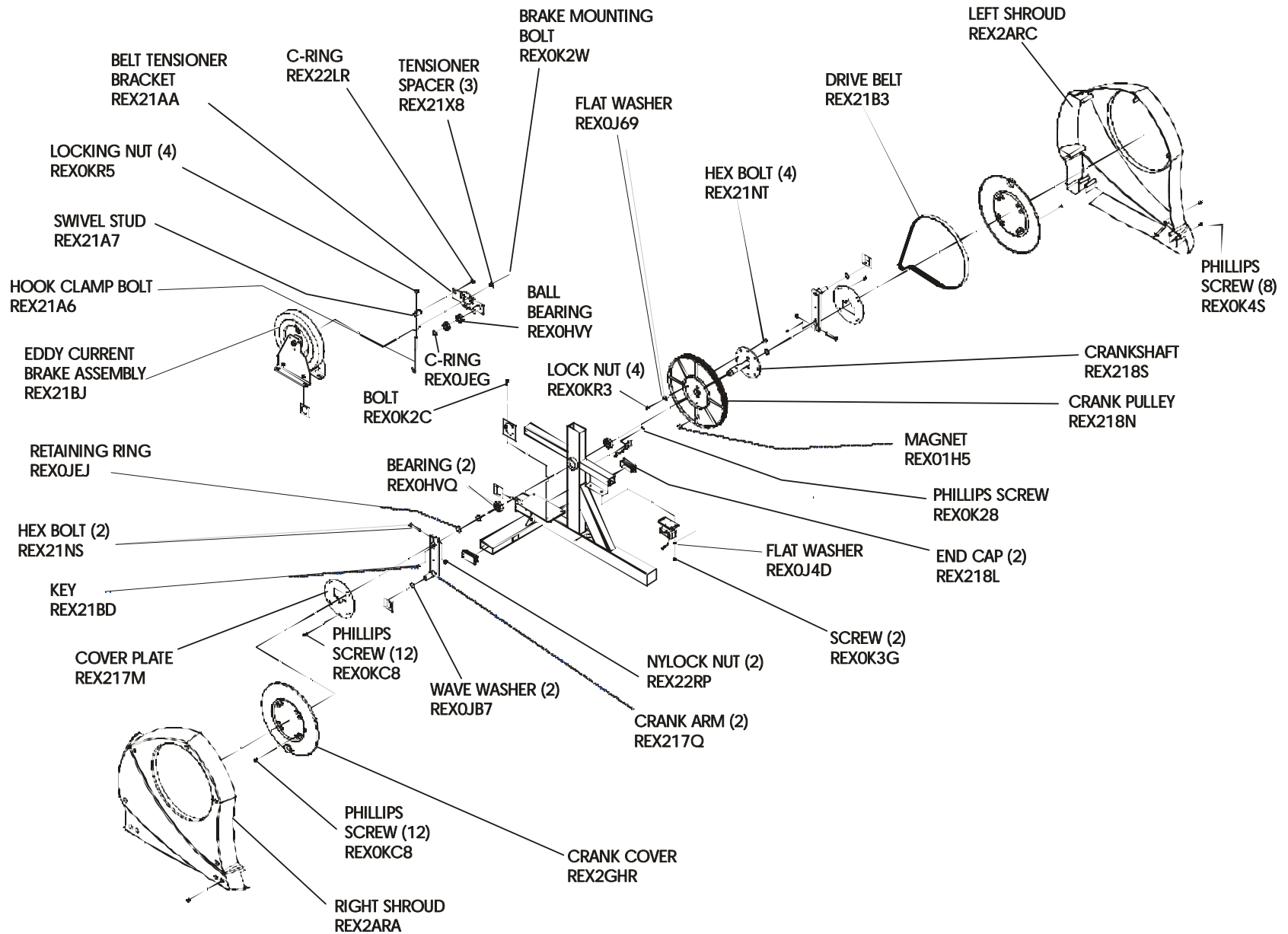

LF Cross-Trainer  
Console, Upright & User Arm Components

X1-XX00-0103

NOT SHOWN: STATIONARY GRIP - REX27SA  
STATIONARY GRIP CAP - REX2BKF

